

CARDOX Systems™



## **BUILD-UP & BLOCKAGE CLEARING SYSTEM FOR SILOS, BINS, HOPPERS & MOST STORAGE VESSELS**

**Efficient, Effective & Reliable...**

**Over 50 years of keeping products free  
& flowing!**

The CARDOX System is recognised as the most **EFFICIENT, RELIABLE** and **COST EFFECTIVE** method of clearing build-ups & blockages whether **grain, flour, maize, soya, sugar, cement, gypsum, coal, fertilizer, catalyst, ore, powder, dust, zinc, aluminium, etc.**

CARDOX can be applied either through small sockets mounted onto the vessel wall or through inspection hatches around the silo.

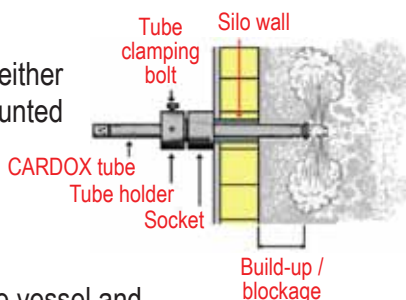

Nobody needs to enter the vessel and CARDOX tubes can be discharged away from the vessel area.

**The powerful CARDOX System provides the ultimate solution to clear even the most difficult build-ups.**

**CARDOX is now available in the following options:**

- PURCHASE** a complete CARDOX System
- RENT** a CARDOX System to tackle your problem
- HIRE** a CARDOX Service Team to undertake the works



### Advantages

- Fully approved by Health & Safety Executive (U.K.)
- Classified as Non-Explosives
- No permit required for usage, or transportation
- No license required for import
- No magazine required for storage
- Immediate return to work site
- Instantaneous results
- Indefinite shelf life
- No shock waves or damaging vibration
- Can be activated in series
- Vertical & horizontal loading

CARDOX Tubes are manufactured to ISO9002 and also carry Rolls Royce Quality Assurance Approval.

## CARDOX Systems™

### How CARDOX works

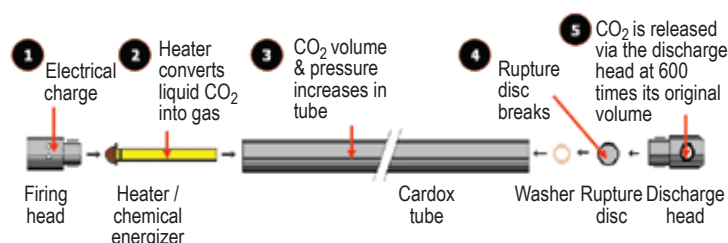

CARDOX has a variety of different tubes for specific applications. Tubes are filled with liquid carbon dioxide (exactly the same as a fire extinguisher). When energized by the application of a small electrical charge, the chemical heater instantly converts the liquid carbon dioxide to a gas. This conversion expands the CO<sub>2</sub> volume and builds up pressure inside the tube until it causes the rupture disc at the end of the tube to burst. This releases the CO<sub>2</sub> - now 660 times the original volume - through a special discharge nozzle to create a powerful heaving force, at pressures up to 40,000 psi (3,000 bar). This all takes place in milliseconds.

This instantaneous build-up in pressure reaches the yielding pressure of the rupture (shear) disc which bursts releasing a heaving mass of carbon dioxide which breaks the surrounding material.

By selecting the thickness of the rupture disc, the power of the tube can be regulated to suit all conditions.

After recovery the tube, the heater, washer and rupture disc are replaced, the liquid carbon dioxide recharged and the tube is ready to be used again.



#### The versatile CARDOX tube recharging unit:

- Can be located anywhere on the plant
- Takes less than one minute to fill CARDOX tubes
- Only needs to be used when build-up / blockage occurs
- Needs minimum amount of maintenance

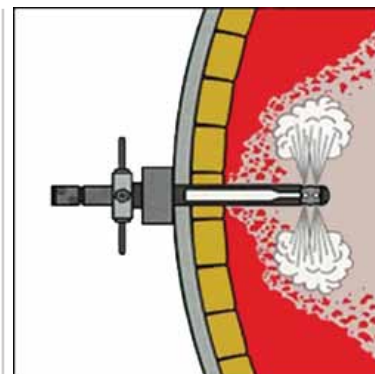
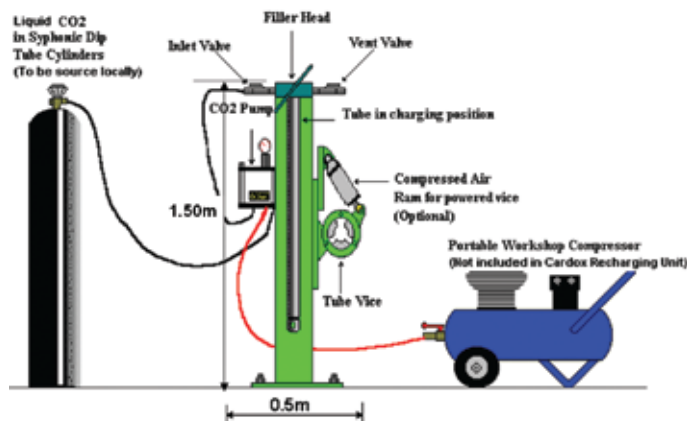

### Advantages

- Fully approved by Health & Safety Executive (U.K.)
- Classified as Non-Explosives
- No permit required for usage, or transportation
- No license required for import
- No magazine required for storage
- Immediate return to work site
- Instantaneous results
- Indefinite shelf life
- No shock waves or damaging vibration
- Can be activated in series
- Vertical & horizontal loading

CARDOX Tubes are manufactured to ISO9002 and also carry Rolls Royce Quality Assurance Approval.

## CARDOX Systems™

### Potential build-up scenario

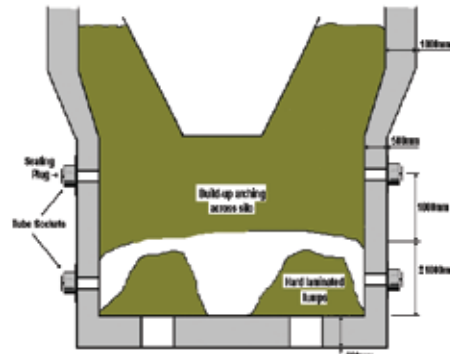

Plug is removed from the socket to reveal build-up.



CARDOX tube is inserted in the tube holder and secured in the socket. Tube is then activated.

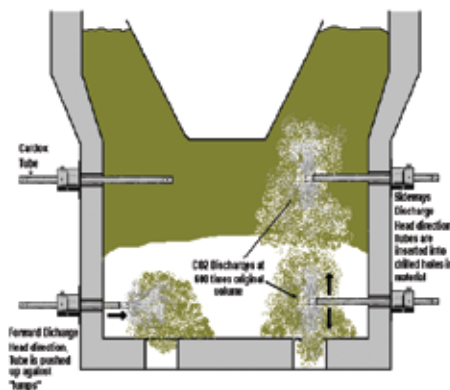

Tube is removed to reveal build-up has been cleared and product is aerated and once again free flowing.

**CARDOX provides the ultimate solution for clearing build-up and blockages in silos, bins, hoppers and most storage vessels.**

Conventional systems involve putting personnel into a confined space. Apart from the workers' natural dislike of doing this type of work, the chances of an accident are relatively high even with appropriate safety equipment.

A CARDOX tube can be inserted into the troubled area from the outside of the bin or hopper removing the need for a worker to go inside. An electrical charge releases compressed carbon dioxide to dislodge the blocked material.

With a safe and powerful carbon dioxide blast, one quick CARDOX tube can remove tons of build-up. Three or four tubes and you're back up to running at capacity with little or no down time.

Compared to other cleaning techniques, the CARDOX System can typically pay for itself in a single application because it is such a fast and efficient method of removing blockages and build-ups.



### Advantages

- Fully approved by Health & Safety Executive (U.K.)
- Classified as Non-Explosives
- No permit required for usage, or transportation
- No license required for import
- No magazine required for storage
- Immediate return to work site
- Instantaneous results
- Indefinite shelf life
- No shock waves or damaging vibration
- Can be activated in series
- Vertical & horizontal loading

CARDOX Tubes are manufactured to ISO9002 and also carry Rolls Royce Quality Assurance Approval.

# ..CONTACT US:

## Talk to Us



A vital part of the service we provide is the ability to understand the customer and its services, ensuring our ability to meet and exceed every client's expectations and customer service levels, every single time.

We work closely with our customers to ensure the safe completion of the projects in which we participate. Since each project is unique, our highly-trained personnel carefully consider and design the safety procedures, equipment, technology and numerous other details required for the successful completion of the project.

Our reputation for detail rests on the shoulders of our high quality personnel. These individuals are highly qualified; moreover, they have undergone rigorous academic and field training. When this is coupled with their years of field experience, the end result is quality you can count on. Whatever size or nature, you are assured that all projects can be carried out with the same professionalism and confidence.

**Peace of heart, peace of mind.**

**Global Services:**  
**CARDOX GLOBAL SERVICES PTE LTD**

10 Bukit Batok Crescent  
#04-03E, THE SPIRE  
Singapore 658079  
Singapore

Tel: (65) 6225 5339 ext 88  
Fax: (65) 6225 6130

Email: [info@cardox.net](mailto:info@cardox.net)

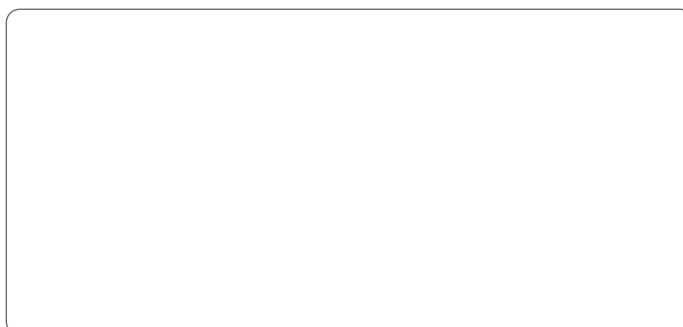

**SILO CLEANING**  
▪  
**BUILD-UP &  
BLOCKAGE CLEARING**  
▪  
**ROCK EXCAVATION**

CARDOX Tubes are manufactured to ISO9002 and also carry Rolls Royce Quality Assurance Approval.